



TV BRACKET SOLUTIONS

THE EQUIP[®] TV WALL MOUNT BRACKET IS A COMPACT BUT STURDY PRODUCT THAT ENSURES A RELIABLE INSTALLATION OF YOUR LCD/PLASMA TV. FOLLOW THE GRAPHIC GUIDE INCLUDED IN THE PACKAGE, YOU CAN INSTALL YOUR TV ON YOUR OWN WITH EASE. THE WALL BRACKET FITS MOST OF THE WALL MATERIALS- BRICK, CONCRETE AND WOOD, MAKING THE IDEAL CHOICE FOR YOU TO SET UP YOUR SCREENS.

23"-55" TILT/SWIVEL TV WALL MOUNT BRACKET

Product N° - 650105

KEY FEATURES

- Free-tilting design for multiple monitor viewing angles
- Max. Load Capacity: 35Kg
- Max. VESA: 400x400
- Swivel and tilt wall mount
- Adjustment knob enables a full range of tilt/swivel action
- Slide-in wall plate provides easy access for attachment and detachment
- Swiveling arm offer maximum viewing flexibility
- VESA standards compliant

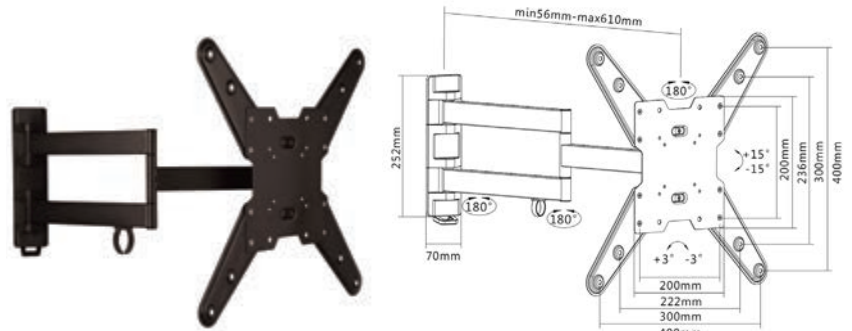

INSTALLATION VIDEO
SCAN HERE:



23"-43" SLIM TV WALL MOUNT BRACKET

Product N° - 650401

KEY FEATURES

- Ultra Slim profile for space saving
- Max. Load Capacity: 25Kg
- Max. VESA: 200x200
- Tool-free tilt adjustment
- VESA standards compliant

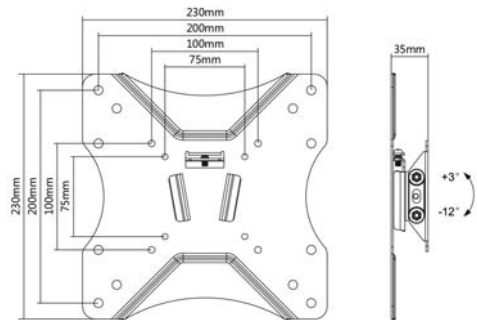

INSTALLATION VIDEO
SCAN HERE:



23"-42" PIVOTING TV WALL MOUNT BRACKET

Product N° - 650402

KEY FEATURES

- Max. Load Capacity: 25Kg
- Max. VESA: 200x200
- Adjustment knob enables a full range of tilt/swivel action
- VESA standards compliant
- Cable clips keep cables organized and protected

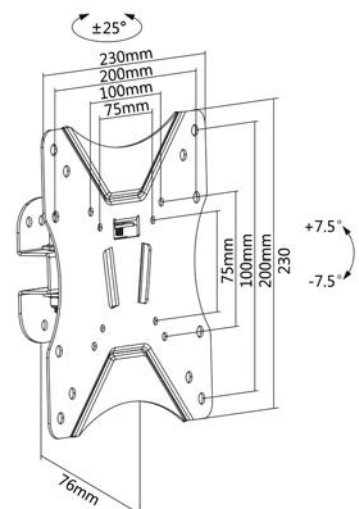

INSTALLATION VIDEO
SCAN HERE:



23"-55" ARTICULATING TV WALL MOUNT BRACKET

Product N° - 650405

KEY FEATURES

- Max. Load Capacity: 30Kg
- Max. VESA: 400x400
- Swivel and tilt wall mount
- VESA standards compliant
- Adjustment knob enables a full range of tilt action
- Free-tilting design for multiple monitor viewing angles
- Full motion mount

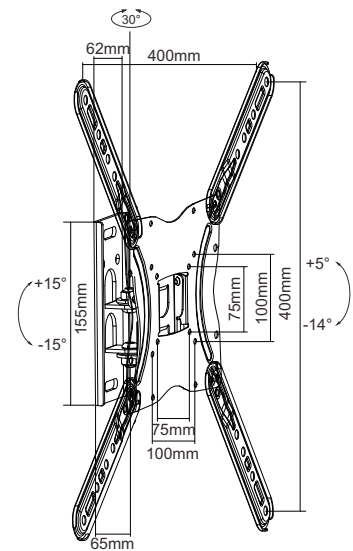

INSTALLATION VIDEO
SCAN HERE:



23"-55" PIVOTING TV WALL MOUNT BRACKET

Product N° - 650406

KEY FEATURES

- Max. Load Capacity: 30Kg
- Max. VESA: 400x400
- Full motion mount
- Adjustment knob enables a full range of tilt action
- Free-tilting design for multiple monitor viewing angles
- VESA standards compliant

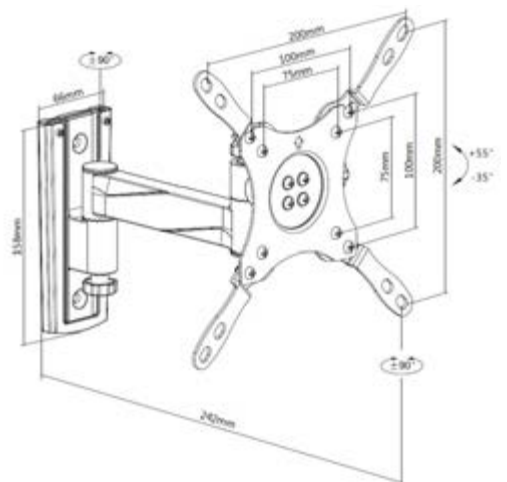

INSTALLATION VIDEO
SCAN HERE:



23"-55" ARTICULATING TV WALL MOUNT BRACKET

Product N° - 650407

KEY FEATURES

- Max. Load Capacity: 30Kg
- Max. VESA: 400x400
- Full motion mount
- Adjustment knob enables a full range of tilt action
- Free-tilting design for multiple monitor viewing angles
- VESA standards compliant

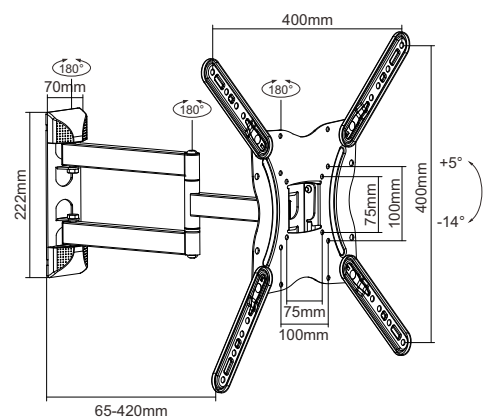

INSTALLATION VIDEO
SCAN HERE:



23"-43" TILT TV WALL MOUNT BRACKET

Product N° - 650408

KEY FEATURES

- Max. VESA: 200x200
- Max. Load Capacity: 35Kg
- Slide-in wall plate provides easy access for attachment and detachment
- Free-tilting design for multiple monitor viewing angles
- VESA standards compliant

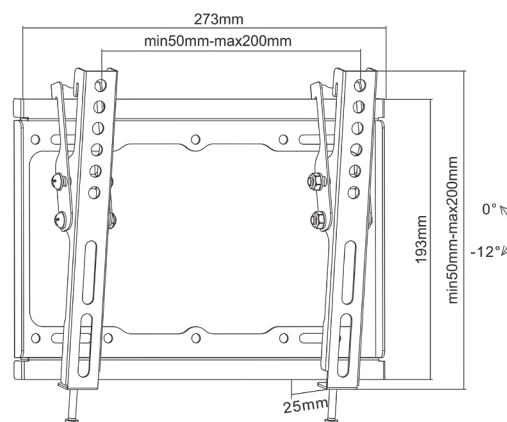

INSTALLATION VIDEO
SCAN HERE:



32"-55" FIXED TV WALL MOUNT BRACKET

Product N° - 650320

KEY FEATURES

- Max. Load Capacity: 55Kg
- Max. VESA: 400x400
- Integrated bubble level assures easy installation alignment
- Slide-in wall plate provides easy access for attachment and detachment
- VESA standards compliant

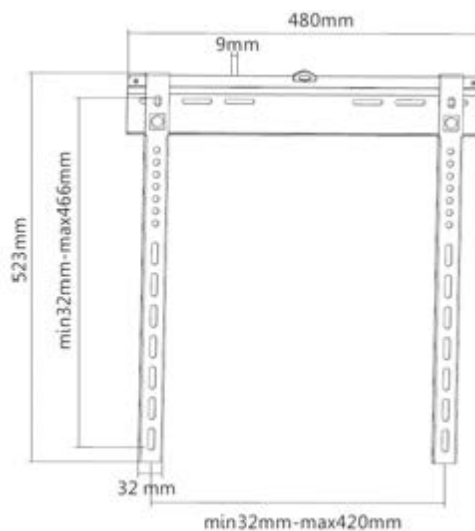

INSTALLATION VIDEO
SCAN HERE:



37"-55" FIXED TV WALL MOUNT BRACKET

Product N° - 650363

KEY FEATURES

- Integrated bubble level assures easy installation alignment
- Slide-in wall plate provides easy access for attachment and detachment
- Max. VESA: 400 x 400
- VESA standards compliant
- Max. Load Capacity: 55Kg

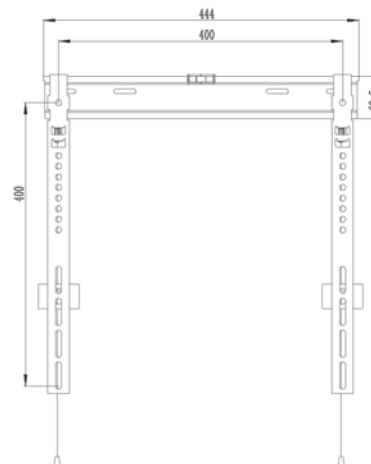

INSTALLATION VIDEO
SCAN HERE:



32"-55" FIXED TV WALL MOUNT BRACKET

Product N° - 650310

KEY FEATURES

- Max. VESA: 400x400
- Max. Load Capacity: 40Kg
- Slide-in wall plate provides easy access for attachment and detachment
- Integrated bubble level assures easy installation alignment
- VESA standards compliant

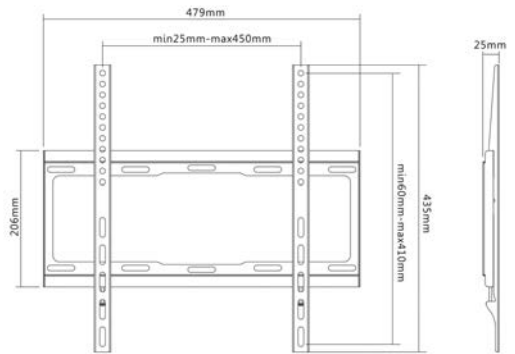

INSTALLATION VIDEO
SCAN HERE:



32"-55" TILT TV WALL MOUNT BRACKET

Product N° - 650311

KEY FEATURES

- Max. Load Capacity: 35Kg
- Max. VESA: 400x400
- Free-tilting design for multiple monitor viewing angles
- Slide-in wall plate provides easy access for attachment and detachment
- Integrated bubble level assures easy installation alignment
- VESA standards compliant

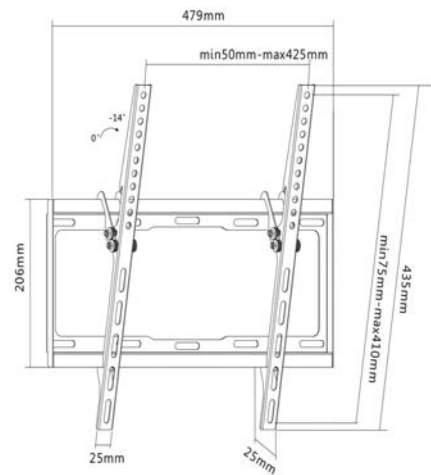

INSTALLATION VIDEO
SCAN HERE:



37"-70" FIXED SLIM TV WALL MOUNT BRACKET

Product N° - 650330

KEY FEATURES

- Max. VESA: 600x400
- Max. Load Capacity: 40Kg
- Slide-in wall plate provides easy access for attachment and detachment
- Integrated bubble level assures easy installation alignment
- VESA standards compliant

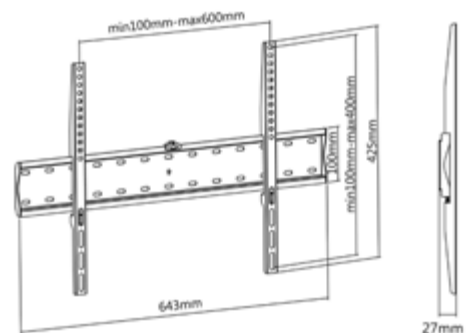

INSTALLATION VIDEO
SCAN HERE:



37"-70" FIXED TV WALL BRACKET

Product N° - 650333

KEY FEATURES

- Max. Load Capacity: 35Kg
- Max. VESA: 600x400
- Ultra-slim design
- Slide-in wall plate provides easy access for attachment and detachment
- Integrated bubble level assures easy installation alignment
- VESA standards compliant

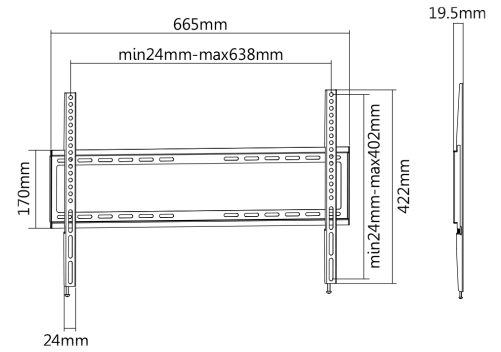

INSTALLATION VIDEO
SCAN HERE:



37"-70" TILT TV WALL BRACKET

Product N° - 650332

KEY FEATURES

- Max. Load Capacity: 40Kg
- Max. VESA: 600x400
- Slide-in wall plate provides easy access for attachment and detachment
- Integrated bubble level assures easy installation alignment
- VESA standards compliant
- Free-tilting design for multiple monitor viewing angles

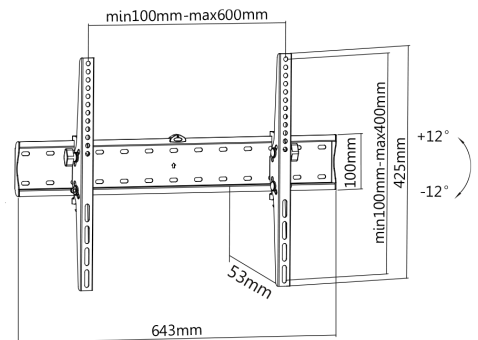

INSTALLATION VIDEO
SCAN HERE:



32"-55" ECONOMY SLIM TILT TV WALL MOUNT BRACKET

Product N° - 650319

KEY FEATURES

- Free-tilting design for multiple monitor viewing angles
- Ultra Slim profile for space saving
- Max. Load Capacity: 35Kg
- Max. VESA: 400x400
- VESA standards compliant

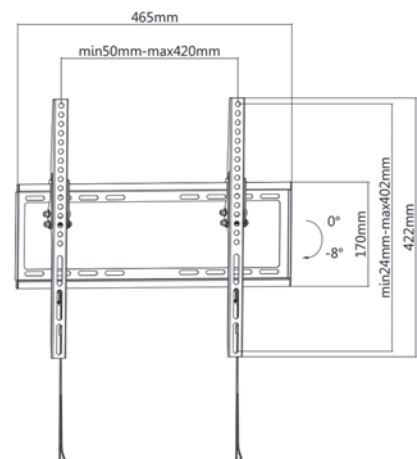

INSTALLATION VIDEO
SCAN HERE:



37"-70" LOW PROFILE TV WALL MOUNT BRACKET

Product N° - 650334

KEY FEATURES

- Max. Load Capacity: 35Kg
- Max. VESA: 600x400
- Ultra-slim design
- Integrated bubble level assures easy installation alignment
- Adjustment knob enables a full range of tilt action
- Easy-grip button for quick angling and locking
- VESA standards compliant

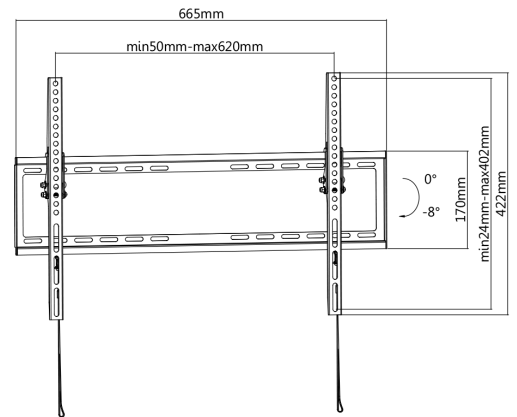

INSTALLATION VIDEO
SCAN HERE:



37"-70" LOW PROFILE TV WALL MOUNT BRACKET

Product N° - 650318

KEY FEATURES

- Integrated bubble level assures easy installation alignment
- Adjustment knob enables a full range of tilt action
- Max. Load Capacity: 50Kg
- Max. VESA: 600x400
- VESA standards compliant

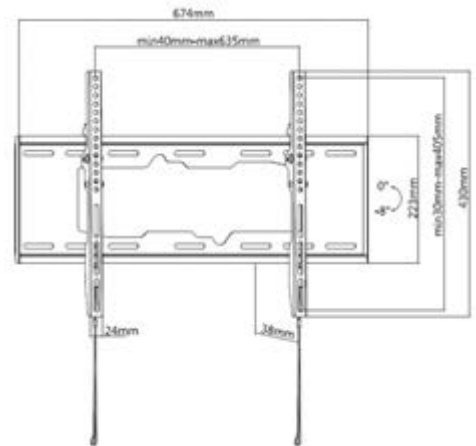

INSTALLATION VIDEO
SCAN HERE:



60"-100" FIXED CURVED TV WALL MOUNT BRACKET

Product N° - 650323

KEY FEATURES

- X-Large Heavy-duty Fixed Curved & Flat Panel TV Wall Mount
- Automatically click-in spring lock helps TV brackets snap into place
- Max. Load Capacity: 100Kg
- Max. VESA: 900x600
- VESA standards compliant

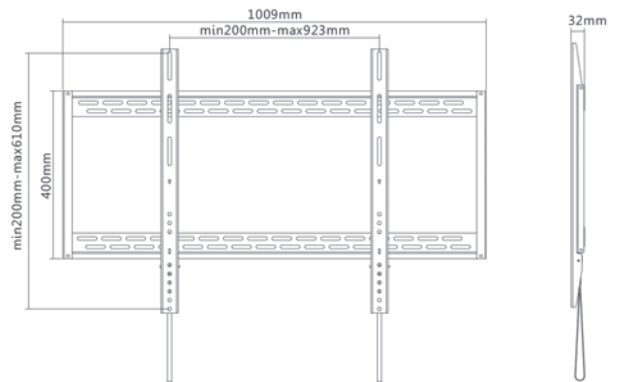

INSTALLATION VIDEO
SCAN HERE:



60"-100" TILT CURVED TV WALL MOUNT BRACKET

Product N° - 650322

KEY FEATURES

- Free-tilting design for multiple monitor viewing angles
- Automatically click-in spring lock helps TV brackets snap into place
- Tool-free tilt adjustment
- Max. Load Capacity: 100Kg
- Max. VESA: 1000x800
- VESA standards compliant

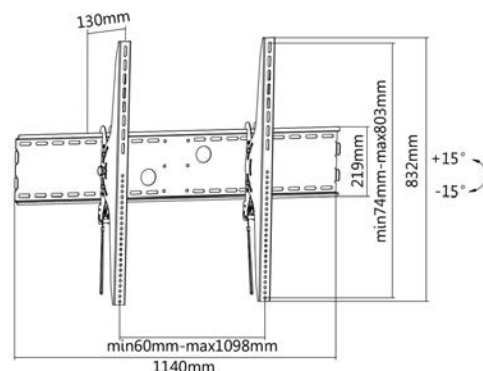

INSTALLATION VIDEO
SCAN HERE:



32"-55" ARTICULATING TV WALL MOUNT BRACKET

Product N° - 650315

KEY FEATURES

- Max. Load Capacity: 50Kg
- Max. VESA: 400x400
- Full motion mount
- VESA standards compliant
- Level adjustment ensures perfect positioning

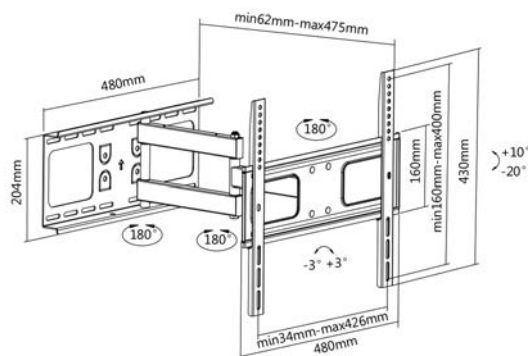

INSTALLATION VIDEO
SCAN HERE:



37"-70" ARTICULATING TV WALL MOUNT BRACKET

Product N° - 650316

KEY FEATURES

- Built-in level adjustment ensures perfect positioning
- Max. Load Capacity: 50Kg
- Max. VESA: 600x400
- VESA standards compliant
- Full motion mount
- Free-tilting design for multiple monitor viewing angles

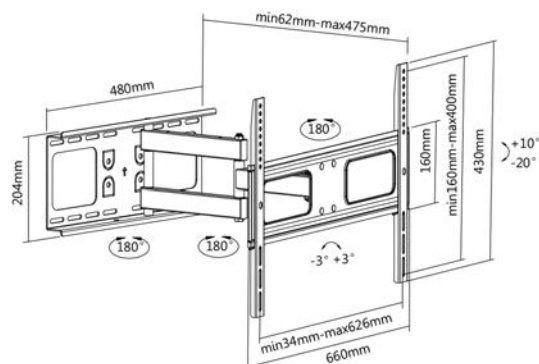

INSTALLATION VIDEO
SCAN HERE:



32"-55" ARTICULATING TV WALL BRACKET

Product N° - 650341

KEY FEATURES

- Max. Load Capacity: 35Kg
- Max. VESA: 400x400
- Full motion mount
- VESA standards compliant
- Free-tilting design for multiple monitor viewing angles
- Level adjustment ensures perfect positioning
- Build-in cable management

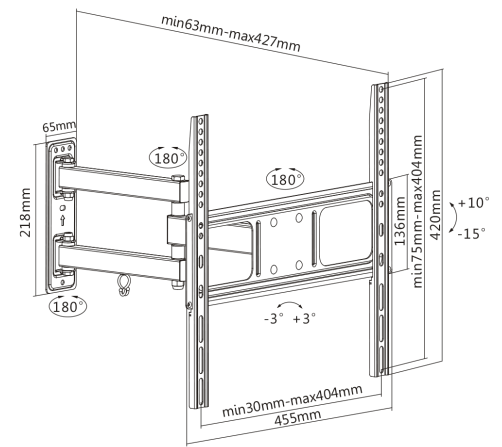

INSTALLATION VIDEO
SCAN HERE:



37"-70" ARTICULATING TV WALL BRACKET

Product N° - 650342

KEY FEATURES

- Max. Load Capacity: 35Kg
- Max. VESA: 600x400
- Full motion mount
- VESA standards compliant
- Free-tilting design for multiple monitor viewing angles
- Level adjustment ensures perfect positioning
- Build-in cable management

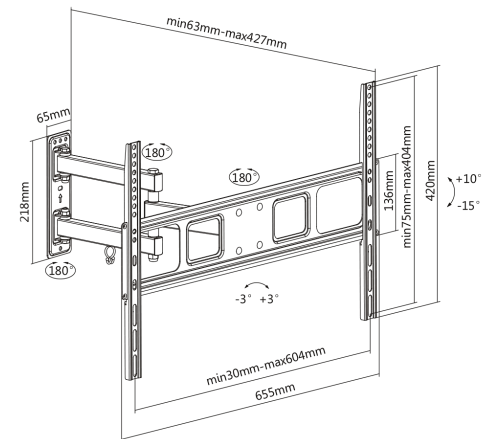

INSTALLATION VIDEO
SCAN HERE:



37"-90" TILT/SWIVEL TV WALL MOUNT BRACKET

Product N° - 650324

KEY FEATURES

- Max. Load Capacity: 75Kg
- Max. VESA: 800x400
- Swiveling arm offer maximum viewing flexibility
- Built-in level adjustment ensures perfect positioning
- Swivel and tilt wall mount
- VESA standards compliant

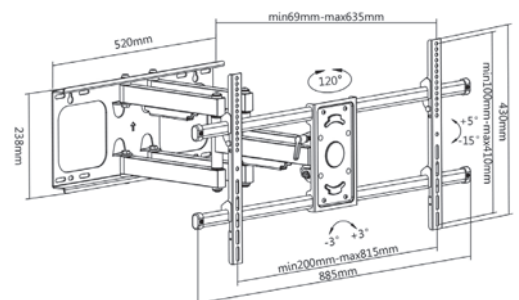

INSTALLATION VIDEO
SCAN HERE:



43"-70" PULL-DOWN TV WALL MOUNT

Product N° - 650326

KEY FEATURES

- Max. Load Capacity: 35Kg
- Max. VESA: 600x400
- VESA standards compliant
- Swivel and tilt wall mount
- Built-in level adjustment ensures perfect positioning
- Gas Piston Auto-Stabilization
- Cable Management: keeps everything organized

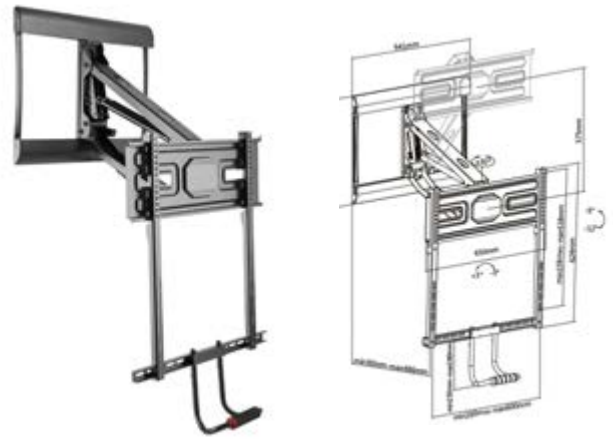

INSTALLATION VIDEO
SCAN HERE:



43"-80" LONG ARM FULL MOTION TV WALL MOUNT BRACKET

Product N° - 650327

KEY FEATURES

- Max. Loading capacity: 50kg
- Max. VESA : 800 x 400
- VESA standard compliant
- Swivel and Tilt wall mount
- Extending Arm: provides a wide range of viewing angles
- Quick-Release Latch: locks/unlocks the display in place
- Build-in Cable management

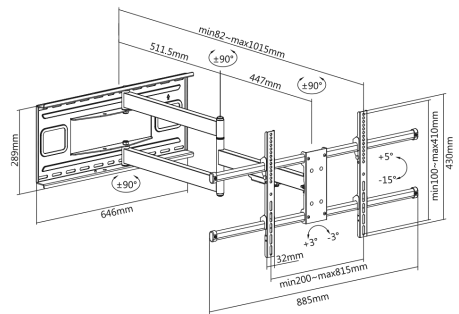

INSTALLATION VIDEO
SCAN HERE:



37"-65" MOTORIZED REMOTE CONTROL TV STAND

Product N° - 650606

KEY FEATURES

- Max. Load Capacity: 50Kg (per screen)
- Max. VESA: 600x400
- VESA standards compliant
- Lift Design: create unique enclosures or cabinets to conceal TVs
- Height adjustment Integrated cable management
- Remote Control Included: for easy movements
- Strong lifting power with low noise level
- Powerful Motor: more stable, strong and durable



INSTALLATION VIDEO
SCAN HERE:

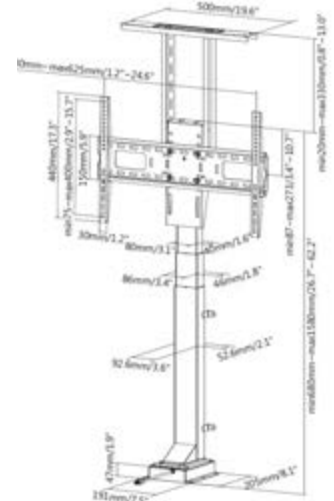
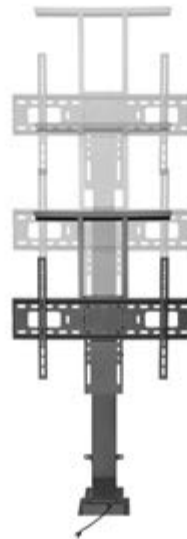

32"-75" MOTORIZED TV SWING MOUNT BRACKET

Product N° - 650336



KEY FEATURES

- Max. Load Capacity: 50Kg
- Max. VESA: 600x400
- VESA standards compliant
- Level adjustment ensures perfect positioning
- Built-in Cable management
- Powerful Motor: more stable, strong and durable
- Remote Control Included: for easy movements
- Collision Avoidance System: safeguards against accidents and injuries
- Low profile: 56mm extra slim design
- Programmable Position Memory Function records the position you like

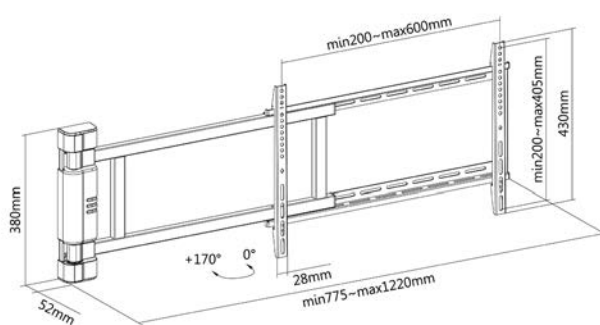

INSTALLATION VIDEO
SCAN HERE:

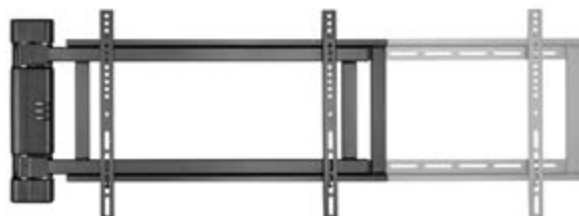

23"-55" FULL MOTION CORNER TV WALL MOUNT BRACKET

Product N° - 650328

KEY FEATURES

- Max. Load Capacity: 45Kg
- Max. VESA: 400x400
- VESA standards compliant
- Split Wall Plate: works on different angled corner walls and save space (also can be installed on flat wall)
- Free-tilting design for multiple monitor viewing angles
- Built-in level adjustment ensures perfect positioning
- Build-in cable management

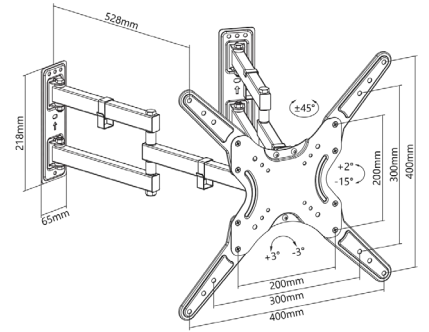

INSTALLATION VIDEO
SCAN HERE:



37"-80" FULL MOTION TV WALL MOUNT BRACKET

Product N° - 650335

KEY FEATURES

- Max. Load Capacity: 60Kg
- Max. VESA: 600x400
- Swiveling arm offer maximum viewing flexibility
- Built-in level adjustment ensures perfect positioning
- Swivel and tilt wall mount
- VESA standards compliant
- Build-in cable management

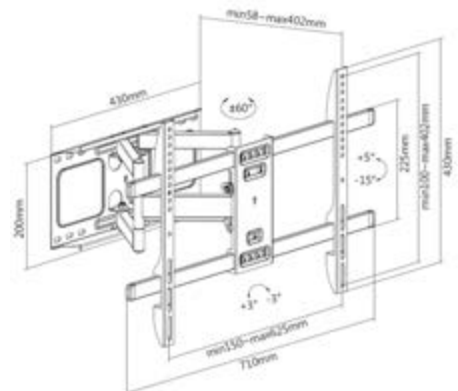

INSTALLATION VIDEO
SCAN HERE:



32"-70" MOTORIZED TV CEILING MOUNT BRACKET

Product N° - 650329

KEY FEATURES

- Max. Load Capacity: 35Kg
- Max. VESA: 600x400
- VESA standards compliant
- Flip down design: allows for easy storage, save space
- Level adjustment ensures perfect positioning
- Built-in Cable management
- Remote Control Included: for easy movements

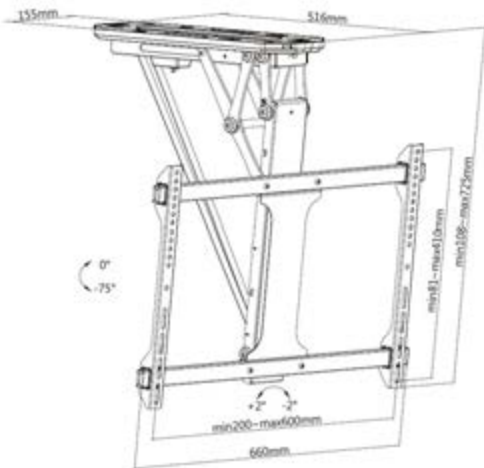

INSTALLATION VIDEO
SCAN HERE:



37"-80" UNIVERSAL ROTATING WALL BRACKET

Product N° - 650331

KEY FEATURES

- Max. Load Capacity: 50Kg
- Max. VESA: 600x400
- VESA standards compliant
- Portrait or Landscape viewing : one solution fits any installation
- Slide-in wall plate provides easy access for attachment and detachment
- Quick-Release latch: locks/unlocks the display in place
- Magnetic strap end : hides itself when not in used

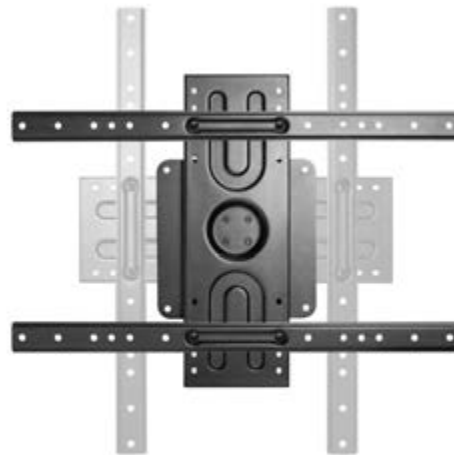

INSTALLATION VIDEO
SCAN HERE:

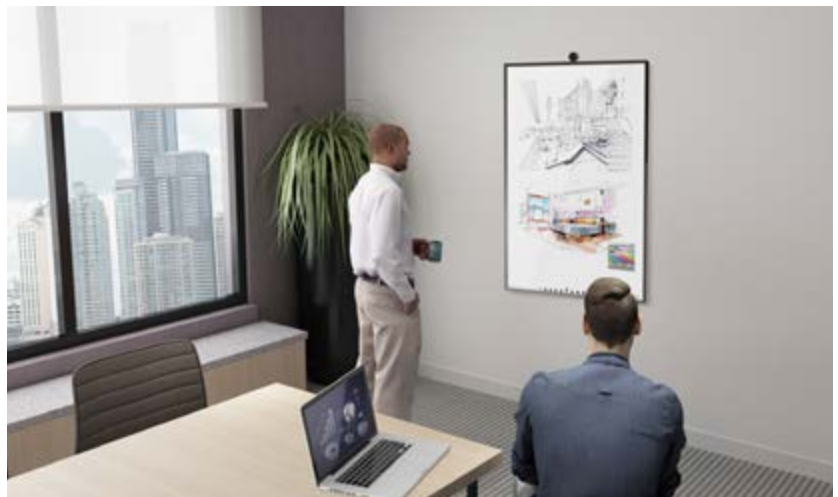
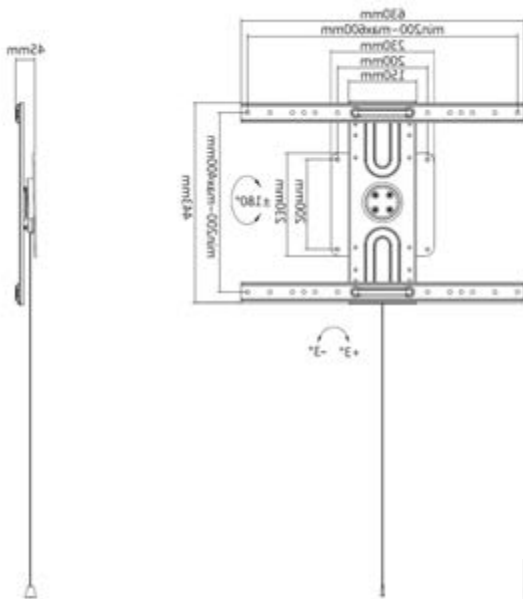



TV STAND SOLUTIONS

32"-55" UNIVERSAL TV TABLETOP STAND

Product N° - 650601

KEY FEATURES

- VESA support Max. 600 x 400
- Max. loading capacity: 40kg
- VESA standards compliant
- Height of the TV is adjustable
- Elegant glossy glass base
- Build-in cable management

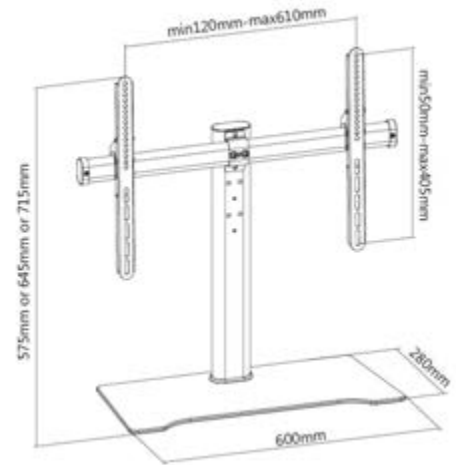

INSTALLATION VIDEO
SCAN HERE:



32"-65" MOTORIZED TV TABLETOP STAND

Product N° - 650610

KEY FEATURES

- Max. Load Capacity: 50Kg
- Max. VESA: 400x400
- VESA standards compliant
- Powerful Motor: more stable, strong and durable
- Collision Avoidance System: safeguards against accidents and injuries
- Height Level adjustment ensures perfect positioning
- Built-in Cable management
- Remote Control Included: for easy movements

INSTALLATION VIDEO
SCAN HERE:

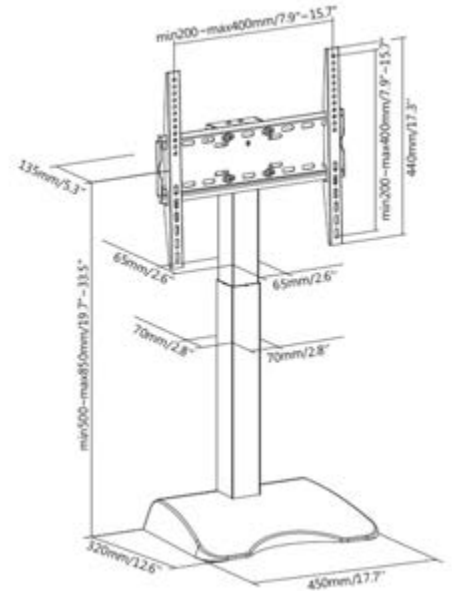

32"-55" UNIVERSAL TV STANDS

Product N° - 650611

KEY FEATURES

- VESA support Max. 400 x 400
- Max. loading capacity: 40kg
- VESA standards compliant
- Height adjustment
- Continuous swivel: for an optimal viewing angel
- Elegant glossy glass base
- Build-in cable management

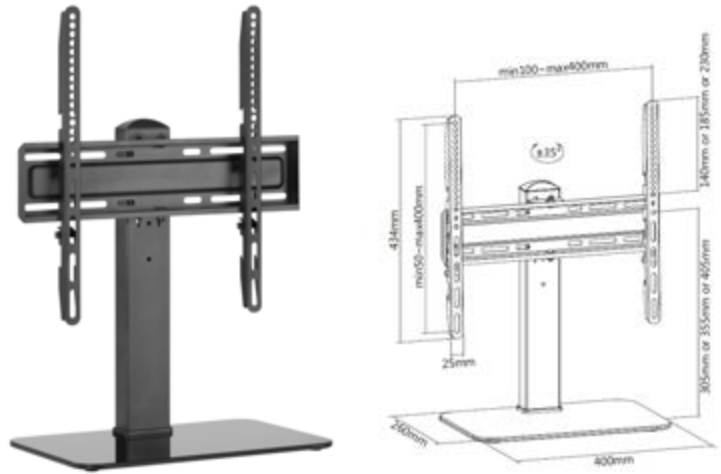

INSTALLATION VIDEO
SCAN HERE:



37"-70" UNIVERSAL TV STANDS

Product N° - 650612

KEY FEATURES

- VESA support Max. 600 x 400
- Max. loading capacity: 40kg
- VESA standards compliant
- Height adjustment
- Continuous swivel: for an optimal viewing angel
- Elegant glossy glass base
- Build-in cable management

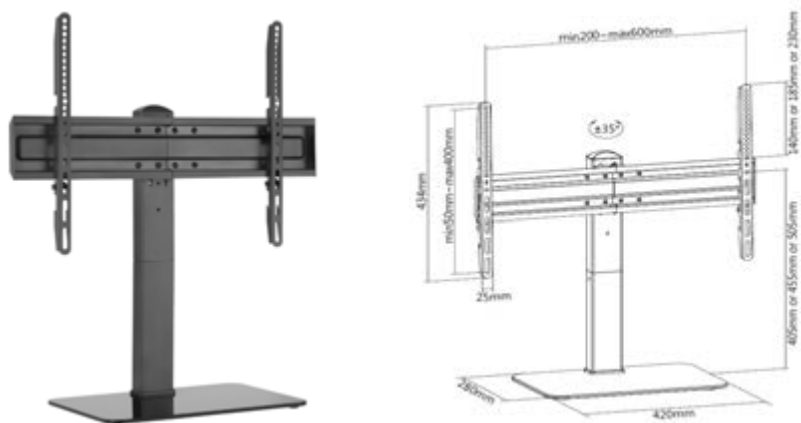

INSTALLATION VIDEO
SCAN HERE:





PROFESSIONAL TV CEILING SOLUTIONS

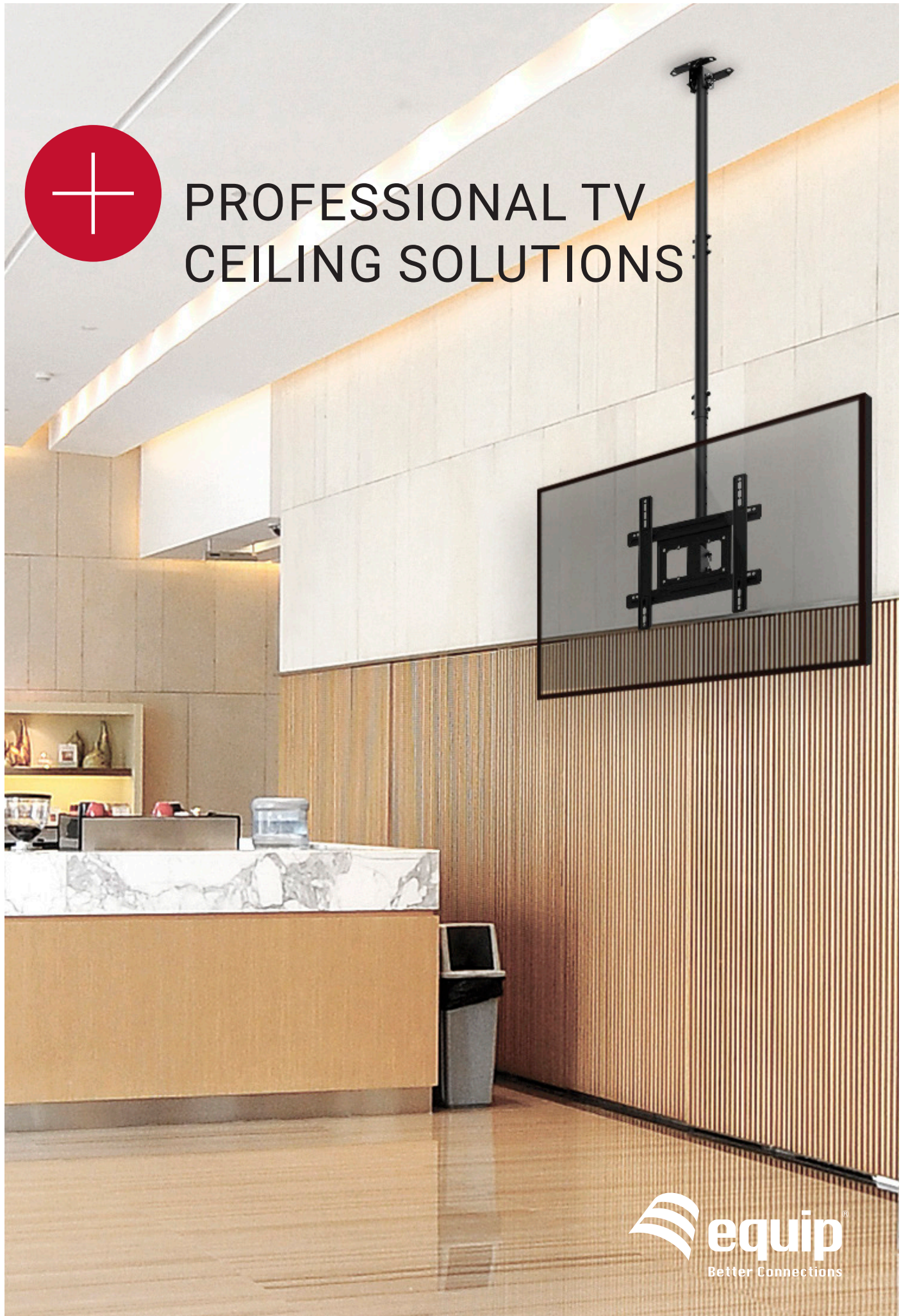

32"-70" CEILING MOUNT TV BRACKET

Product N° - 650321

KEY FEATURES

- Telescopic height adjustment for optimum visibility
- Freely angling and swiveling for different viewing angles
- Removable VESA attachment for easy installation
- Integrated cable management
- Max. Load Capacity: 50Kg
- Max. VESA: 400x400
- VESA standards compliant

INSTALLATION VIDEO
SCAN HERE:

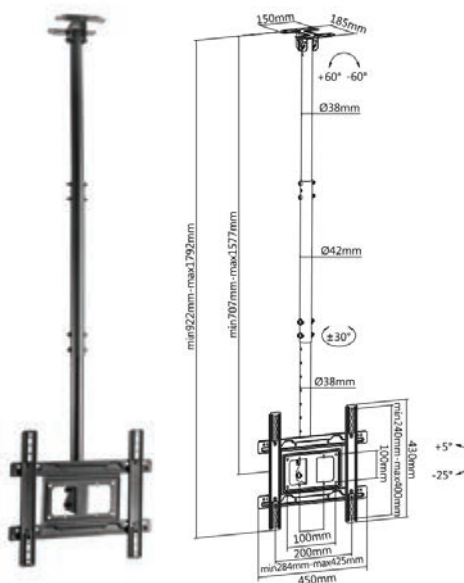

39"-75" CEILING MOUNT DUAL SCREEN TV BRACKET

Product N° - 650370

KEY FEATURES

- Compatible with landscape and portrait mounting
- Integrated bubble level assures easy installation alignment
- Adjustment knob enables a full range of tilt/swivel action
- VESA standards compliant
- Built-in Cable management
- Max VESA support: 600 x 400
- Max Loading weight : 40kgs (per screen)

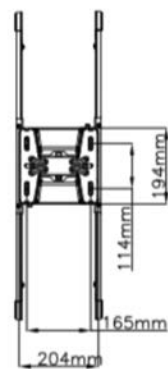
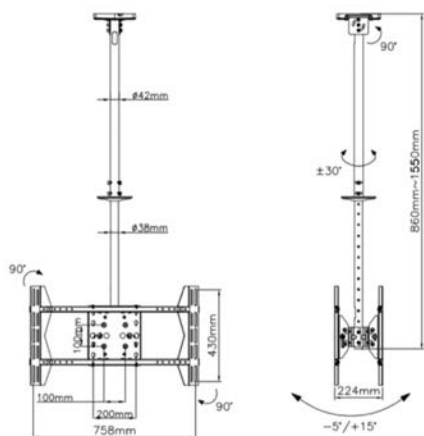

32"-65" CEILING MOUNT TRIPLE SCREEN TV BRACKET

Product N° - 650371

KEY FEATURES

- Compatible with landscape and portrait mounting
- Integrated bubble level assures easy installation alignment
- Adjustment knob enables a full range of tilt/swivel action
- Max. VESA: 600x400
- VESA standards compliant
- Built-in Cable management
- Max. Load Capacity: 30Kg per screen

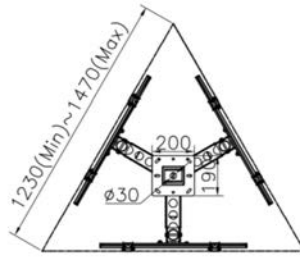
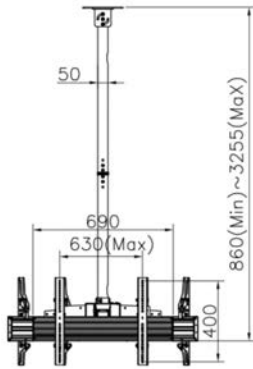

32"-65" CEILING MOUNT QUAD SCREEN TV BRACKET

Product N° - 650372

KEY FEATURES

- Integrated bubble level assures easy installation alignment
- Adjustment knob enables a full range of tilt/swivel action
- Compatible with landscape and portrait mounting
- Built-in Cable management
- Max. VESA: 600x400
- VESA standards compliant
- Max. Load Capacity: 30Kg per screen

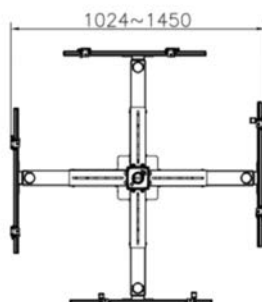
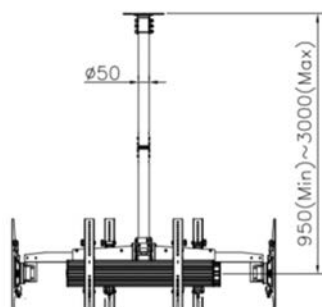

45"-55" DUAL SCREEN CEILING MOUNT

Product N° - 650373

KEY FEATURES

- support TV 45"-55"
- Max. Load Capacity: 50Kg (per screen)
- Max. VESA: 600x400
- Free-tilting & Swiveling Design
- Sturdy and lightweight aluminum construction
- Level adjustment ensures perfect positioning
- Integrated cable management system
- Anti-Theft Locking Hole: for additional security preventing any unwanted removal

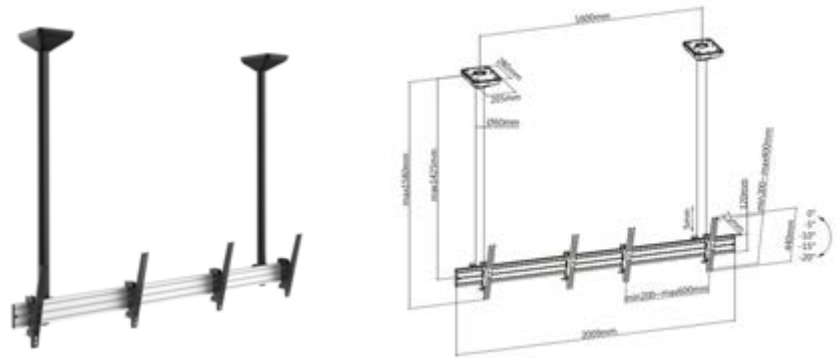

45"-50" TRIPLE SCREEN CEILING MOUNT

Product N° - 650374

KEY FEATURES

- support TV 45"-50"
- Max. Load Capacity: 50Kg (per screen)
- Max. VESA: 600x400
- Free-tilting & Swiveling Design
- Sturdy and lightweight aluminum construction
- Level adjustment ensures perfect positioning
- Integrated cable management system
- Anti-Theft Locking Hole: for additional security preventing any unwanted removal





PROJECTOR BRACKET SOLUTIONS

PROJECTOR CEILING MOUNT BRACKET

Product N° - 650700

KEY FEATURES

- Sturdy and lightweight aluminum construction
- Integrated cable management system
- Height adjustment: 130/220mm
- Suitable for projectors with a pitch circle diameter of 225-315mm
- Max. Load Capacity: 10Kg/22Lbs
- Rotation: 360°

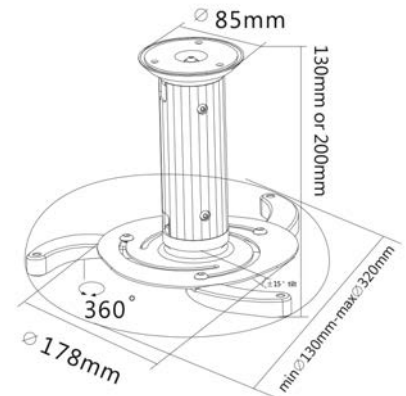

INSTALLATION VIDEO
SCAN HERE:



PROJECTOR CEILING WALL MOUNT BRACKET

Product N° - BLACK 650702 | WHITE 650703

KEY FEATURES

- Sturdy and lightweight steel construction
- Height adjustment : 430-650mm
- Suitable for projectors with a pitch circle diameter of 225-315mm
- Integrated cable management system
- Max. Load Capacity: 20Kg / 44 Lbs

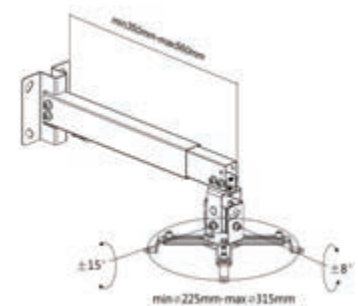

SHORT THROW PROJECTOR WALL MOUNT BRACKET

Product N° - 650704

KEY FEATURES

- Tool-free length adjustment
- Integrated cable management system

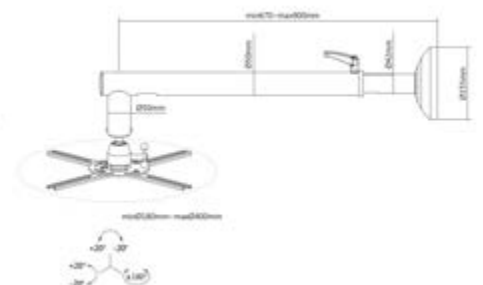



PROFESSIONAL DIGITAL SIGNAGE SOLUTIONS

37"-65" MODULAR PUSH-IN POP-OUT TV WALL MOUNT BRACKET

Product N° - 650355

KEY FEATURES

- Compatible with landscape and portrait mounting
- Push-In Pop-Out for easy access and after service
- Built-in Cable management
- Modular mount with unlimited video display configurations
- Max. VESA: 600x400
- VESA standards compliant
- Max. Load Capacity: 30Kg per screen

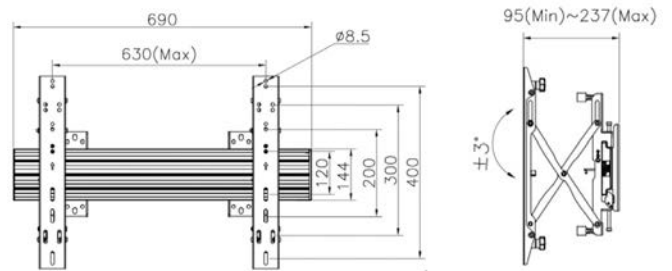

INSTALLATION VIDEO
SCAN HERE:



19"-70" PUSH-IN POP-OUT TV WALL MOUNT BRACKET

Product N° - 650325

KEY FEATURES

- Compatible with landscape and portrait mounting
- Push-In Pop-Out for easy access and after service
- Modular mount with unlimited video display configurations
- Max. VESA: 600x400
- Built-in Cable management
- Max. Load Capacity: 50Kg per screen

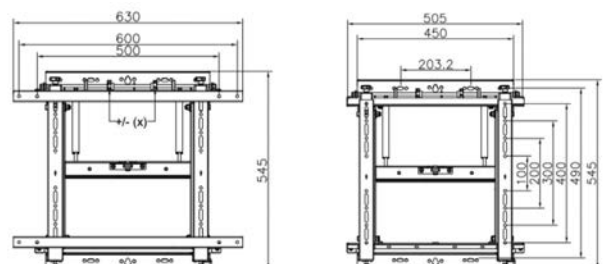

INSTALLATION VIDEO
SCAN HERE:



37"-70" POP-OUT VIDEO WALL MOUNT BRACKET

Product N° - 650351



KEY FEATURES

- Max VESA: 600 x 400
- Max Loading weight: 45kgs
- Built-in Cable management
- VESA standards compliant
- Anti-Theft Locking Hole: for additional security preventing
- Modular mount with unlimited video display configurations
- Pop-Out Lock System: ensures safety by reducing the possibility of accidental pop-outs
- Pop-Out extension provides quick access for installation and maintenance
- Compatible with landscape mounting

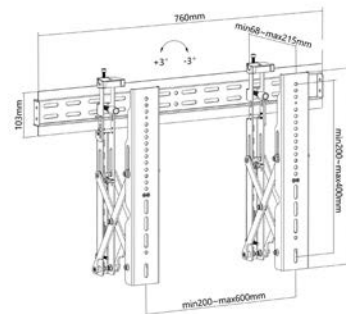

INSTALLATION VIDEO
SCAN HERE:



45"-70" POP-OUT VIDEO WALL MOUNT BRACKET

Product N° - 650352



KEY FEATURES

- Max VESA: 600 x 400
- Max Loading weight: 70kgs
- Built-in Cable management
- VESA standards compliant
- Anti-Theft Locking Hole: for additional security preventing
- Modular mount with unlimited video display configurations
- Effortless Micro-Adjustments: allow seamless display alignment
- Pop-Out Lock System: ensures safety by reducing the possibility of accidental pop-outs.
- Effortless Micro-Adjustments allow seamless display alignment
- Innovative Quick-Release for easy installation
- Compatible with landscape and portrait mounting

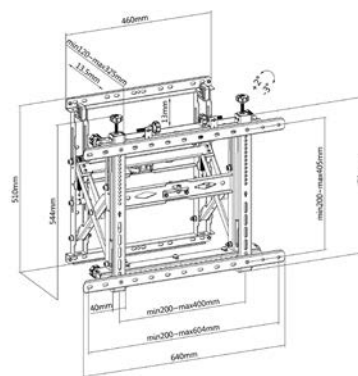

INSTALLATION VIDEO
SCAN HERE:





www.equip-info.net



Technical specifications are subject to change without notice.
© Copyright Digital Data Communications GmbH. All Rights Reserved.
Im Defdahl 10F, 44141 Dortmund, Germany

DISTRIBUTED BY

2023 EN